

Silicon Phototransistor

OP570 Series



Features:

- SMD plastic package
- High photo sensitivity
- Fast response time
- Choice of four lead configurations
- IR transmissive plastic package

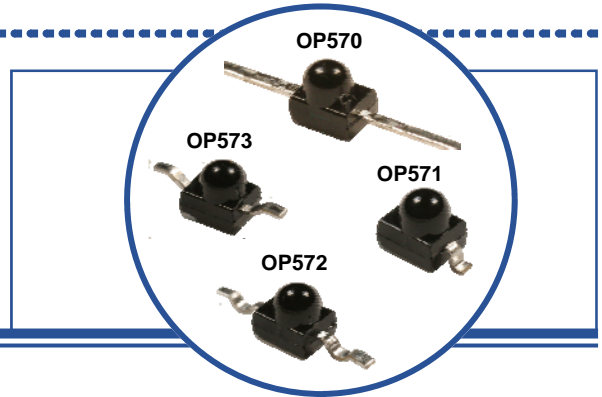

Description:

Each device in this series is an NPN silicon phototransistor mounted in an opaque plastic SMD package, with an integral molded lens that enables a narrow acceptance angle and a higher collector current than devices without a lense.

The **OP570** series has four lead configurations and is compatible with most automated mounting equipment. *The OP570 series is mechanically and spectrally matched to the OP270 series infrared LEDs.*

Please refer to Application Bulletins 208 and 210 for additional design information and reliability (degradation) data.

Applications:

- Non-contact position sensing
- Datum detection
- Machine automation
- Optical encoders
- IrDA
- Reflective and transmissive sensors

Ordering Information			
Part Number	Sensor	Viewing Angle	Lead Length
OP570	Phototransistor	25°	Axial
OP571			Gull Wing
OP572			Yoke
OP573			Rev. Gull

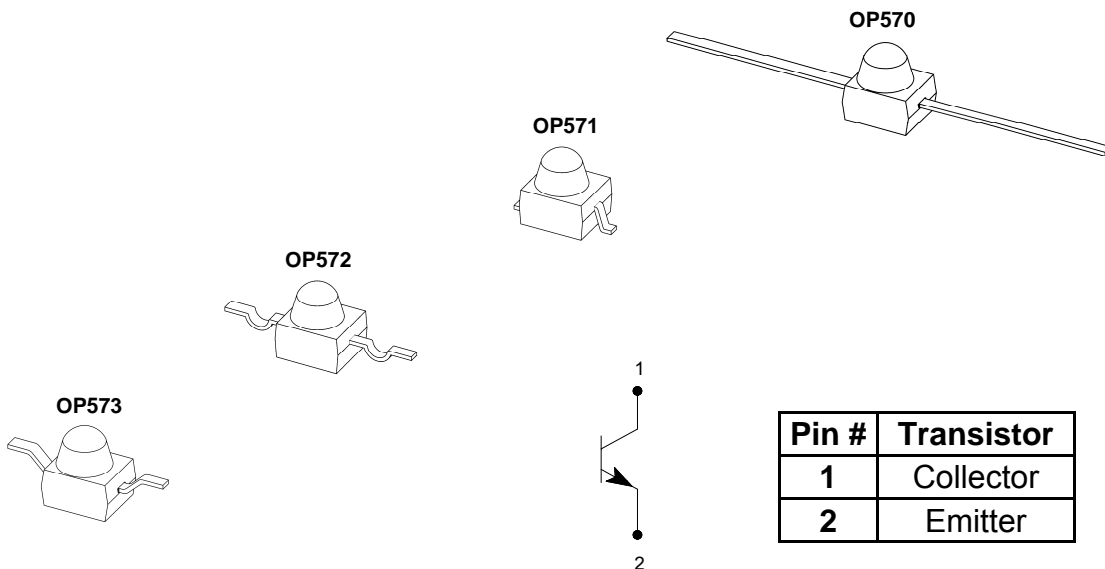

RoHS

OPTEK reserves the right to make changes at any time in order to improve design and to supply the best product possible.

OP573

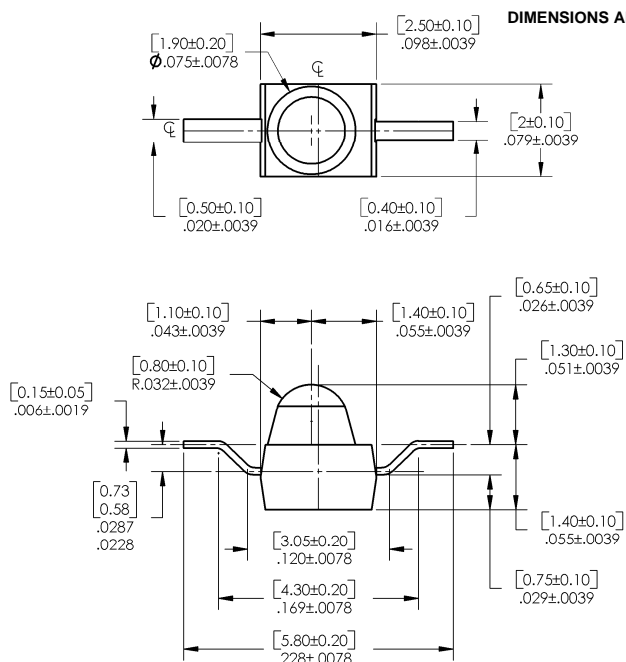

OP570

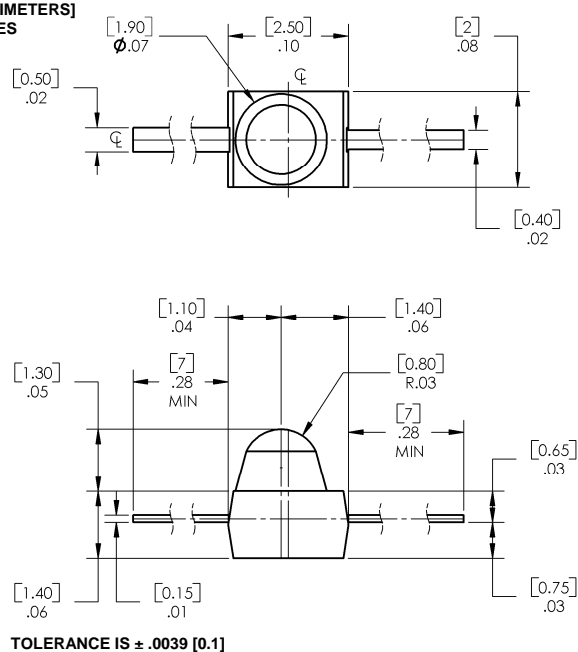

OP571

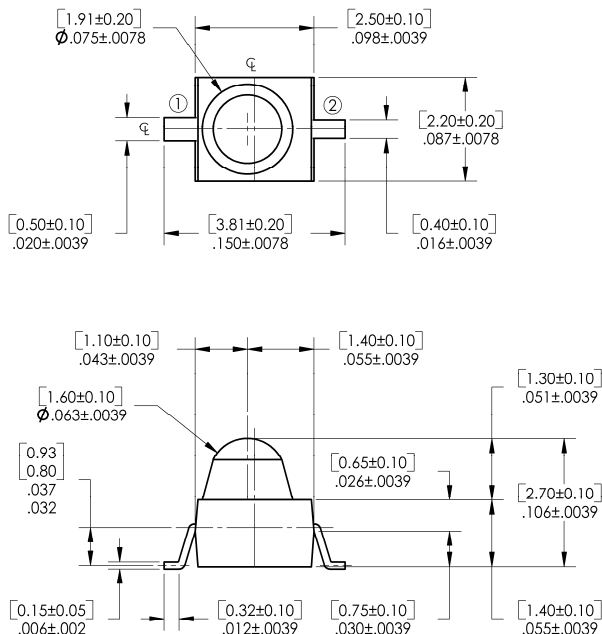

OP572

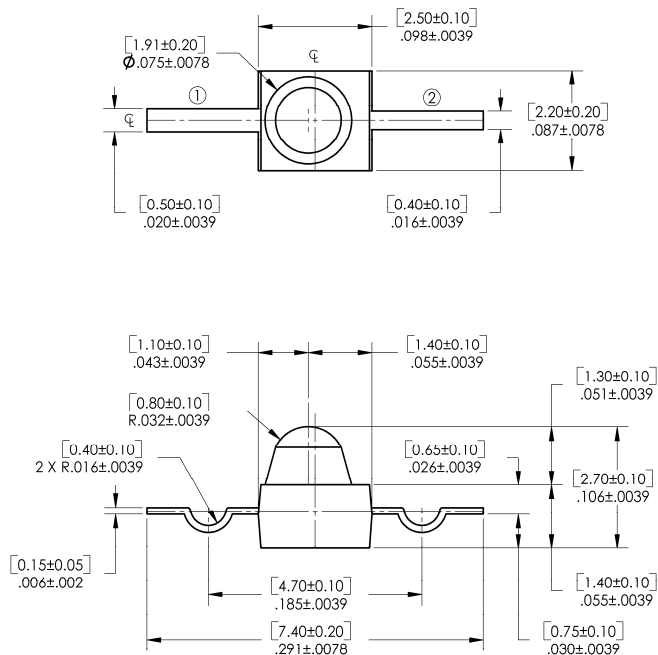

Pin #	Transistor
1	Collector
2	Emitter

OPTEK reserves the right to make changes at any time in order to improve design and to supply the best product possible.

Absolute Maximum Ratings ($T_A=25^\circ\text{C}$ unless otherwise noted)

Storage Temperature Range	-40° C to +85° C
Operating Temperature Range	-25° C to +85° C
Collector-Emitter Voltage	30 V
Emitter-Collector Voltage	5 V
Collector Current	20 mA
Lead Soldering Temperature [1/16 inch (1.6 mm) from case for 5 seconds with soldering iron]	260° C ⁽¹⁾
Power Dissipation	130 mW ⁽²⁾

Notes:

1. Solder time less than 5 seconds at temperature extreme.
2. Derate linearly at 2.17 mW/° C above 25° C.

Electrical Characteristics ($T_A = 25^\circ\text{C}$ unless otherwise noted)

SYMBOL	PARAMETER	MIN	TYP	MAX	UNITS	TEST CONDITIONS
Input Diode						
I_C (ON)	On-State Collector Current	2.5	-	-	mA	$V_{CE} = 5.0\text{ V}, E_E = 5.0\text{ mW/cm}^2$ ⁽¹⁾
$V_{CE(SAT)}$	Forward Voltage	-	-	0.4	V	$I_C = 100\ \mu\text{A}, E_E = 2.0\text{ mW/cm}^2$ ⁽¹⁾
I_{CEO}	Reverse Current	-	-	100	nA	$V_{CE} = 5.0\text{ V}, E_E = 0$ ⁽²⁾
$V_{BR(CEO)}$	Wavelength at Peak Emission	30	-	-	V	$I_C = 100\ \mu\text{A}$
$V_{(BR)ECO}$	Emission Angle at Half Power Points	5	-	-	V	$I_E = 100\ \mu\text{A}$

Notes:

1. Light source is an unfiltered GaAl LED with a peak emission wavelength of 935nm and a radiometric intensity level which varies less than 10% over the entire lens surface of the phototransistor being tested.
2. To calculate typical collector dark current in μA , use the formula $I_{CEO} = 10^{(0.04 T_A - 3.4)}$ where T_A is the ambient temperature in ° C.

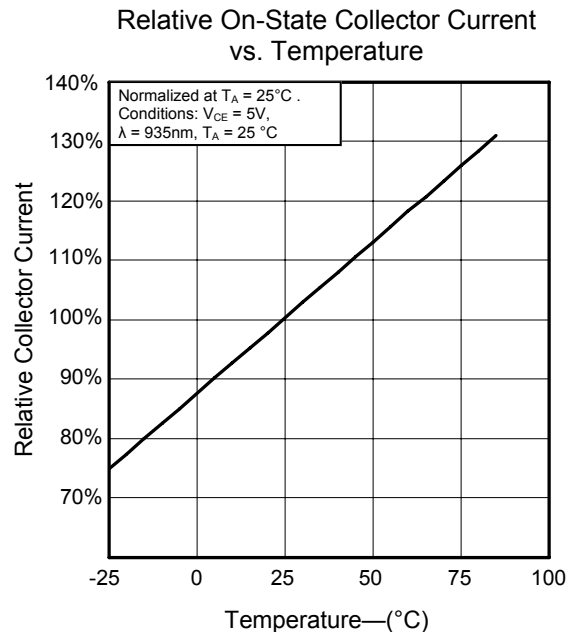
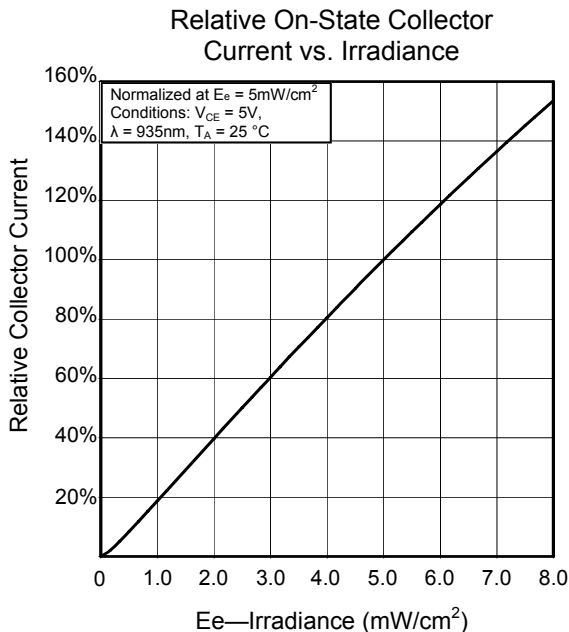

OPTEK reserves the right to make changes at any time in order to improve design and to supply the best product possible.

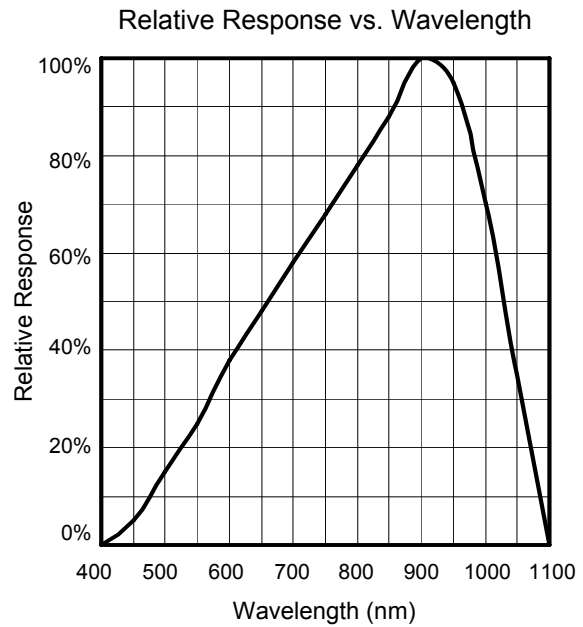
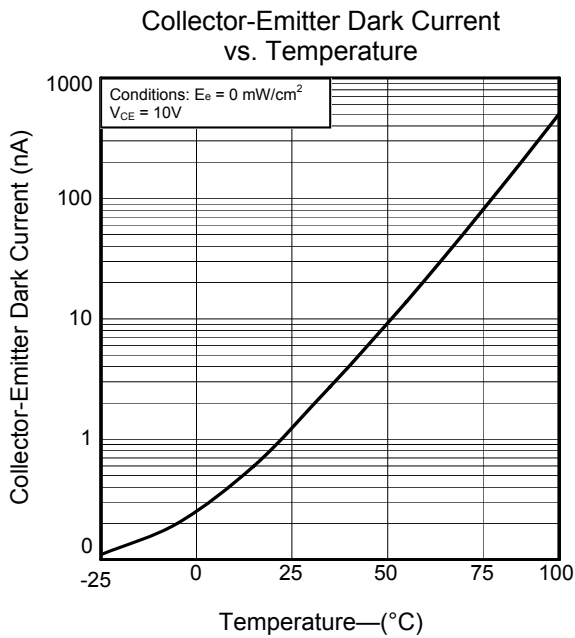
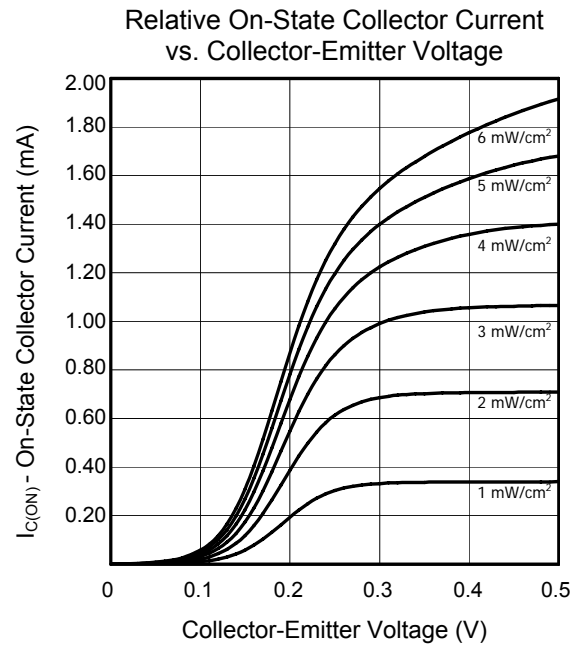
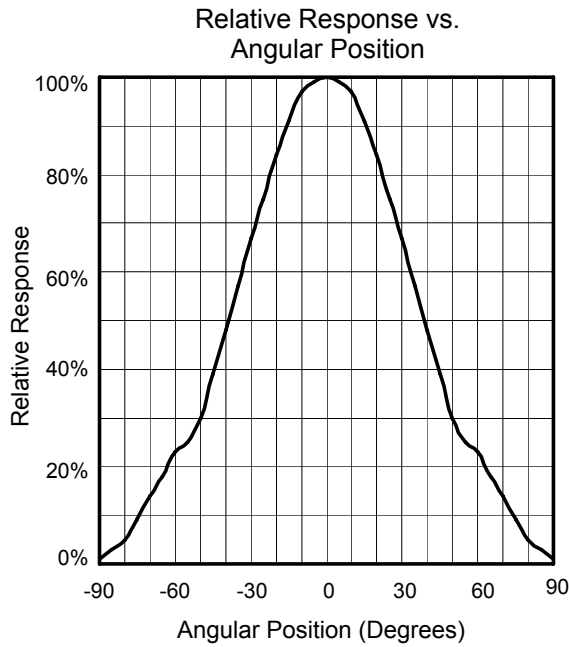

OPTEK reserves the right to make changes at any time in order to improve design and to supply the best product possible.